



# Javo Plus M2.0



## A welcome addition to the Plus Series



The Javo Plus M2.0 is suitable for 10 up to 32cm pots. The potting machine is available in different pot track configurations, each for its own purpose. Apart from the standard configuration with adjustable tray support, it is also possible to provide the pot track with a barerootsystem. Adjustable chutes bring substrate onto a flexible plate behind the pot, for the possibility to put extra soil in the pot. This is truly a versatile potting machine.

### Characteristics

Changing the pot size can be done within a couple of minutes, without using any tools, because of the patented adjustment system of the pot track. The smooth action pot track disc has a central adjustment for pot height and diameter, without adjusting the pot supports. The soil elevating system is provided with rubber belts and stainless steel elevator blades, which make this potting machine quiet and extremely low-maintenance. The pot track and soil elevating system can be electronically adjusted, so the pot track speed and soil supply can be arranged optimally. The mechanical stop in the soil elevating system prevents the system to get overloaded with substrate and takes care of a minimal structure change of the substrate.



# JAVO



A NOBELS GROUP COMPANY

for generations of growth



# Javo Plus M2.0

## Advantages

- Pot track and elevator can be electronically adjusted.
- Simple to use.
- Central adjustment for pot size.
- Very precise adjustment of the soil supply.
- Minimal structure change of the substrate.
- The unique soil-return-system prevent any jam and waste of the substrate.
- Central adjustment makes the machine very suitable for processing more than 1 pot size.
- Easy to integrate with other systems.
- Soil elevator equipped with rubber belts, to make the machine quiet and maintenance-low.
- Stainless steel elevator blades.
- CE marked and complies with the Machine directive 2006/42/EG or with the UL/CSA guidelines for the US and Canada.

## Available options

- Suitable for square pots.
- Pots double.
- Continuous pot track running system.
- Soil bin extension for 1.600 litre extra capacity.
- Bare-root-system, for extra soil supply on the pot track.
- Various pot dispensers.
- Brush unit.
- (Double) drill installation.
- Compaction rollers.
- Various possibilities and placements for pot take-off.
- Multiple electrical possibilities.

## Technical specifications

<b>Suitable for:</b>	round pots, optional for square pots
<b>Pot sizes:</b>	10 up to 32 cm
<b>Capacity:</b>	1.240 - 3.100 pots per hour *
<b>Measurements (l x w x h):</b>	4.755 mm x 2.211 mm x 2.230 mm
<b>Soil bin capacity:</b>	1.100 litre
<b>Weight:</b>	2.160 kg
<b>Voltage:</b>	400V 50Hz 3~ +N +PE / 220V 60Hz 3~ +PE
<b>Power:</b>	3,5 kW
<b>Power connection:</b>	16A, 5 pins CEE plug

*\* Mentioned capacities depend on machine configuration, pot sizes and substrate.*

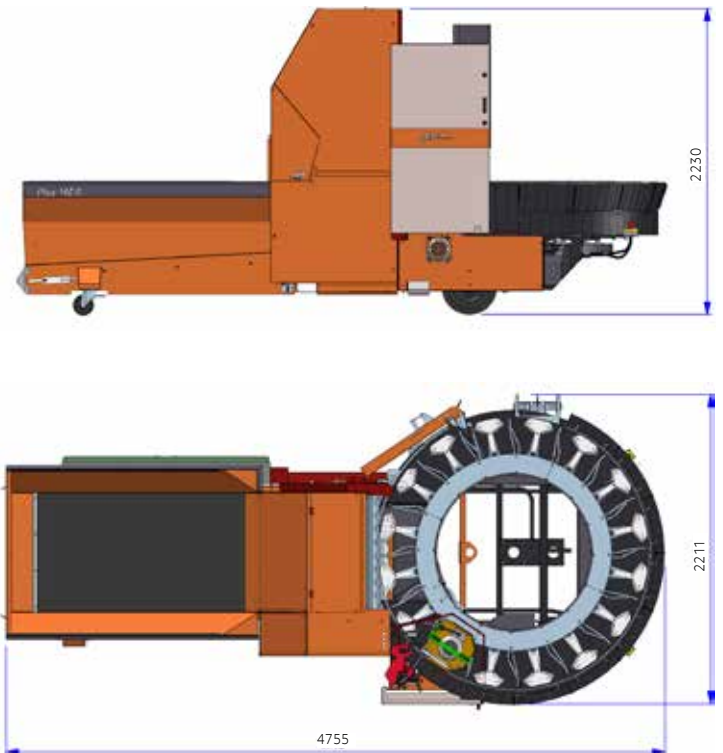

## Contact

**More information about the Javo Plus M2.0 or a demonstration?  
Please contact us.**

**Bulb Trade Park 1, 2211 SW Noordwijkerhout, The Netherlands**  
T: +31 (0) 252 343 121 E: info@javo.eu

[www.javo.eu](http://www.javo.eu)

**JAVO**