



Javo Easytopper



Accurate and quick protection against weeds and moss



The Easytopper delivers a cover layer to the top of the pot to prevent weed development and retain moisture – saving money for nurseries and greenhouses. The machine is suitable for round or square pots and pot sizes can be changed quickly and easily with a single adjustment. It spreads a layer of mulch over the top of the pot and underneath the plant to eliminate weeds and moss. The amount of mulch can be adjusted quickly and easily. The adjustable speed feed system means the top layer can be varied to suit your requirements and it takes just seconds to change pot sizes the Javo Easytopper.

How does the machine work

The tested feed system guarantees an even and quick feed. The dosing plate, combined with the belt in the machine's bunker ensures quick and easy adjustment.



An easily-adjustable slide plate accurately spreads material on the pot. Round pots are rotated to distribute the material evenly everywhere underneath the plant. Prior to exiting the machine, the pot is levelled-off and the excess material is returned to the soil bin, ensuring a clean environment and reduced material costs.

JAVO



A NOBELS GROUP COMPANY

for generations of growth



Javo Easytopper

Advantages

- Soil bin can be supplied with mulch from three sides
- Easy-to-adjust and works well with multiple pot sizes
- Low maintenance
- Simple operation
- The 4 wheels (2 swivel wheels) make it highly maneuverable
- Easy to connect to other systems
- Variable set-up, depending on customer's requirements (left or right design)
- Accurate adjustment using the machine's dosing plate and belt
- Electronic speed adjustable feed belts

Available options

- Soil bin extension
- Electronic speed adjustment and reverse switch for the elevator
- Various brush options
- Multiple electrical options
- Various options for brushing soil out of the pot
- Shaker unit

Technical details

Suitable for:	round pots and square pots
Pot sizes:	8 - 32 cm (3¼" - 13") (12 litres)
Capacity:	Up to 6.000 pots per hour (depending on machine configuration, pot and soil)
Measurements (l x w x h):	3.160 mm x 1.730 mm x 2.210 mm
Soil bin capacity:	770 liter
Weight:	600 kg
Voltage:	400V 50Hz 3~ +N +PE / 220V 60Hz 3~ +PE
Power:	2,4 kW
Power connection:	16A, 5 pins CEE plug

** Mentioned capacities depend on machine configuration, pot sizes and substrate.*

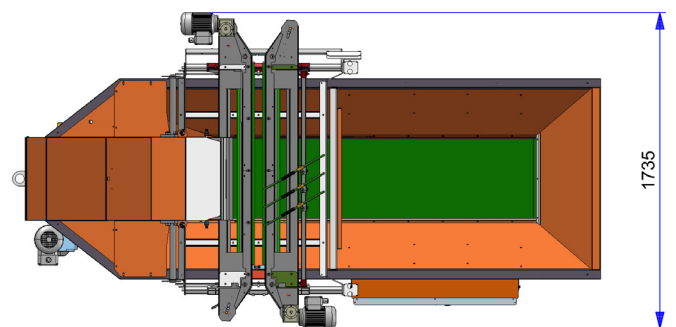
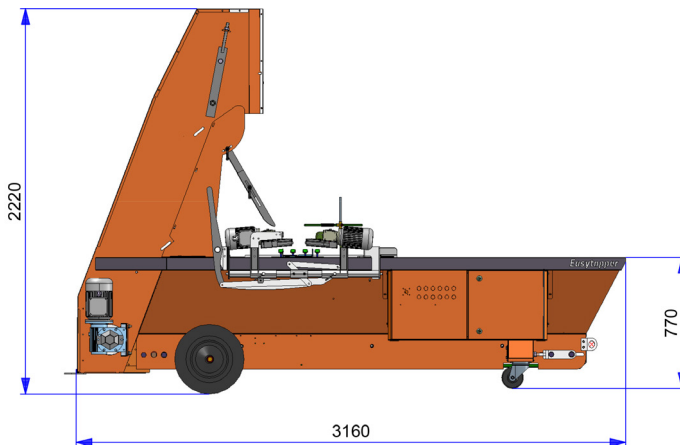

Contact



More information about the Javo Easytopper or a demonstration?
Please contact us.

Bulb Trade Park 1, 2211 SW Noordwijkerhout, The Netherlands
T: +31 (0) 252 343 121 E: info@javo.eu

www.javo.eu

