

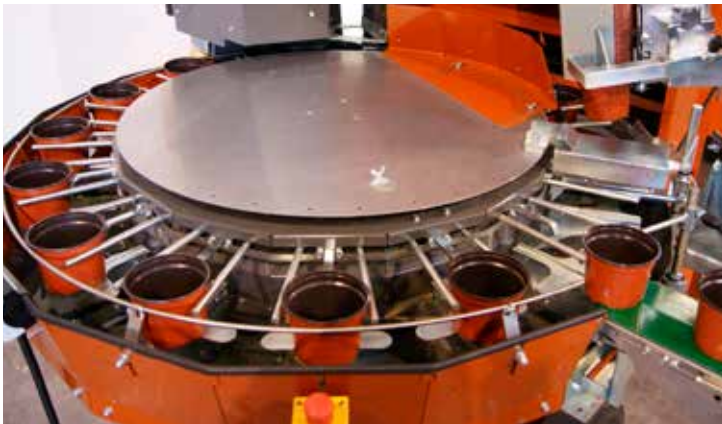

# Javo Plus



## The most compact machine in the Plus Series



The Javo Plus has 16 pot positions and is suitable for 9-23cm pots. The machines in the Plus series are characterized by the round pot track, suitable for round and (optional) square pots. Like the other members of the Plus family, the Plus uses a fast, easy central adjustment for quick changes between pot sizes, saving time and money. With a gear drive pot track and belt-driven elevator, the Plus series is quiet and extremely low-maintenance. Machines in this series: Plus, Plus M2.0, Plus X.

### How does the machine work

The soil belt brings the substrate to the elevator in steps. When using a pot dispenser, it places the pots onto the pot track and smoothly moves the pots.

The substrate falls into the pots via the elevator. The scraper brings the remaining soil back to the soil bin.

The drill optionally makes a hole in the substrate. By choosing to use a pot take-off, the pots will be placed to a conveyor belt automatically. Otherwise the pots can be taken off from the pot track by hand.



# JAVO



A NOBELS GROUP COMPANY

for generations of growth



# Javo Plus

## Advantages

- Frequency controlled elevator and pot track.
- Simple to use.
- Includes its own soil bunker with soil belt and guide belts.
- Very precise adjustment of the soil supply.
- Minimal structure change of the substrate.
- The unique soil-return-system prevent any jam and waste of the substrate.
- Central adjustment makes the machine very suitable for processing more than 1 pot size.
- Very mobile, because of its 4 wheels (2 swivel wheels with brake).
- Easy to integrate with other systems.
- CE marked and complies with the Machine directive 2006/42/EG or with the UL/CSA guidelines for the US and Canada.

## Available options

- Suitable for square pots.
- Suitable for 5-8cm pots.
- Pots double next to each other.
- Continuous pot track running system.
- Soil bin extension for 1.600 litre extra capacity.
- Bare-Root-System.
- Various pot dispensers.
- Brush unit.
- (Double) drill installation.
- Compaction rollers.
- Various possibilities for pot take-off.
- Pneumatic heavy duty swivel wheels with tow bar.
- Javo Dispenser.
- Every RAL-colour available.
- Multiple electrical possibilities.

## Technical details

<b>Suitable for:</b>	round pots, optional for square pots
<b>Pot sizes:</b>	9 - 23 cm, optional from 5 cm
<b>Capacity:</b>	780 - 3.840 pots per hour *
<b>Measurements (l x w x h):</b>	4.200 mm x 1.600 mm x 2.000 mm
<b>Soil bin capacity:</b>	1.100 litre
<b>Weight:</b>	1.750 kg
<b>Voltage:</b>	400V 50Hz 3~ +N +PE / 220V 60Hz 3~ +PE
<b>Power:</b>	3 kW
<b>Power connection:</b>	16A, 5 pins CEE plug

\*Mentioned capacities depend on machine configuration, pot sizes and substrate.

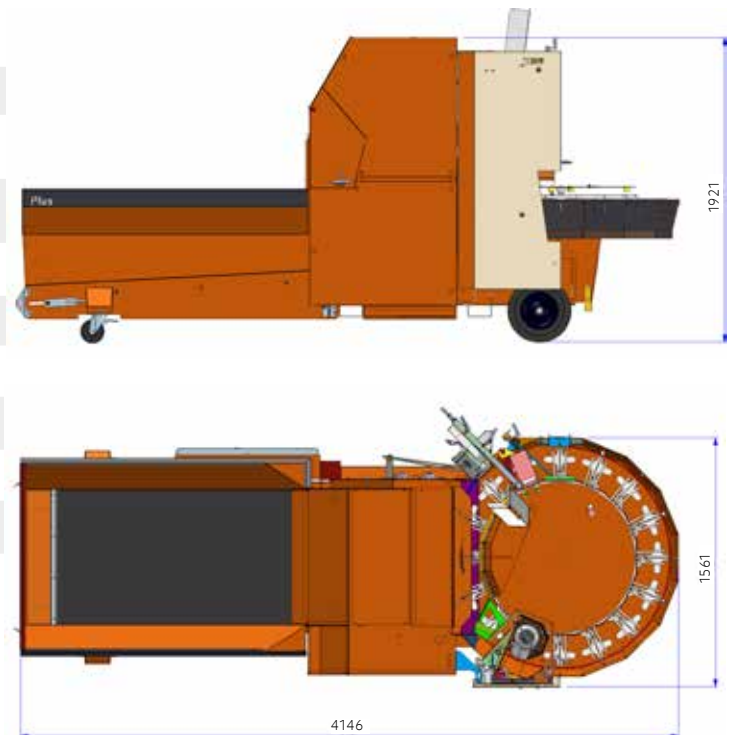

## Contact



More information about the Javo Plus or a demonstration?  
Please contact us.

Bulb Trade Park 1, 2211 SW Noordwijkerhout, The Netherlands  
T: +31 (0) 252 343 121 E: info@javo.eu

[www.javo.eu](http://www.javo.eu)

